

## LIMITED WARRANTY

Lind Electronics, LLC. (LIND) warrants the circuit assembly portion of products manufactured by it to be free of defects in material and workmanship for a period of 1 year from the date of purchase under normal use. During this warranty period, LIND will, at its option, repair or replace the product at no charge for parts or labor when the product is returned postage paid as a complete unit to LIND. Proof of purchase and a letter explaining the problem must accompany the returned unit.

This warranty does not apply if any part of the adapter, its cables or connection jacks have been altered, subjected to abuse, accident or misuse. This warranty excludes incidental or consequential damage resulting from the product or the use of the product. This warranty is in lieu of all other warranties expressed or implied and no person is authorized to assume for LIND any other liability in conjunction with this product. The warranty gives you, the purchaser, specific legal rights and you may have other rights which may vary from state to state and country to country.

The LIND product you are purchasing has not been designed for, or certified for use in, life support applications. Any such use is at your own risk. LIND ELECTRONICS, LLC. HEREBY EXPRESSLY DISCLAIMS ANY IMPLIED WARRANTIES OF MERCHANTABILITY OR FITNESS FOR A PARTICULAR PURPOSE. Lind Electronics, LLC. will not be liable for any claims, awards, damages or other liability arising out of the use of LIND products for life support applications whether in the nature of direct, indirect, consequential, special or punitive damages.

For assistance call Lind Technical Support at (800) 659-5956 or email us at [techsupport@lindelectronics.com](mailto:techsupport@lindelectronics.com).

Lind, Lind Electronics, and the Lind Logo are trademarks of Lind Electronics, LLC. All other registered trademarks and trademark names are the property of their respective owners.



lindelectronics.com  
952.927.6303  
info@lindelectronics.com  
SUPSL-F00235 0825

14850 Deveau Place  
Minnetonka, MN 55345

© 2025 LIND ELECTRONICS



## LIND BATTERY CHARGER FOR DELL RUGGED BATTERIES



The Lind Battery Charging System consists of one Master Controller and one or more Charging Bays. It also requires power from a Dell AC power adapter to power the system.

Each Charging Bay is for use with a particular series of Dell batteries and will not charge a different series of batteries. Charging Bays for different types of batteries can be connected together and used in the same system. Up to 16 Charging Bays can be connected in one system.

The Master Controller has a sliding door on its side which will expose a power jack to plug the Dell AC power adapter in to supply the power for the Charging Bays. The AC adapter should be rated at 45W to 330W and may have come with your tablet/ computer or may be purchased separately. The higher the wattage rating of the AC adapter the more batteries that may be charged at the same time. If not enough power is available the Master Controller will determine which batteries will charge first and what sequence the rest will charge in as other batteries finish their charging. Once charged, a battery can be removed and another discharged battery may be inserted into that Charging Bay.

## PREPARATION

---

**WARNING!** – Remove power to the system before assembling or disassembling the system. A Charging Bay should not be added or removed with power applied to the system.

## ASSEMBLY

---

**STEP 1:** Turn the Master controller over so its bottom is facing up. Push the two locking fingers of the End Cap away from the Master Controller while also applying a slight downward pressure to these fingers until the End Cap disengages and slides partially off the Master Controller. Slide the End Cap off and set aside.

**STEP 2:** Turn the Master Controller right side up. Take a Charging Bay module and align it so it is along side the Master Controller module (about 2” higher than the Master Controller). While pushing the Charging Bay module against the Master Controller slide it down so their interlocking grooves engage each other. Slide the Charging Bay module down until it is fully seated – the locking fingers of the Charging Bay module should lock onto the bottom of the Master Controller.

**STEP 3:** If another Charging Bay is to be added, align it along the assembled section and slide it down while pushing it together to engage the interlocking grooves. Continue to slide it down until fully seated.

**STEP 4:** Continue step 3 until up to 16 Charging Bays have been connected to the Master Controller.

**STEP 5:** Take the end cap from step 1, align it with the last Charging Bay and slide it down to fully seat it.

**STEP 6:** Mount system where it will be used.

**NOTE:** The Battery Charging System is to be mounted on a flat horizontal surface. It may be mounted at an angle with the back of its base angled up to 30° above the horizontal. In this case the unit must be secured to the mounting surface.

**STEP 7:** Slide the door on the side of the Master Controller to expose either the 4.5mm jack or the 7.4mm jack that matches the Dell AC power adapter being used and plug the cord into the Master Controller.

**STEP 8:** Apply power to the Dell AC adapter. Once the Master Controller recognizes the AC adapter it will turn on its green indicator. Then as the Master Controller communicates with each Charging Bay for the first time that bay's indicator will flash green for 1 second. The system is now ready for use.

- Four quick amber blinks followed by 4 quick green blinks = Temporary battery fault. Charging stopped if started. May resume if fault goes away. If fault persists for more than 30 seconds fault indication changes to battery failure indicated above. Note: this indication may be seen when a battery is first inserted into a bay if the battery circuitry has entered a sleep mode.
- Two quick amber flashes followed by two quick green flashes = Unsupported battery, no charging allowed
- Blinking red = Battery temperature is colder than 32°F(0°C) or hotter than 122°F(50°C). Charging of battery is stopped. Resumes when back in normal temperature range.

## BATTERY CHARGING

---

Each battery charging bay will use up to 20W of power while charging its battery. The size of the Dell power adapter will determine how many bays may charge at the same time. See the list below for the number of batteries that can charge simultaneously when using various Dell adapters to power the system.

- 45W adapter = 2 batteries simultaneously
- 65W adapter = 3 batteries simultaneously
- 90W adapter = 4 batteries simultaneously
- 130W adapter = 6 batteries simultaneously
- 180W adapter = 8 batteries simultaneously
- 240W or larger adapter = 9 batteries simultaneously

If more bays are connected than the number listed above the additional bays will wait until the previous batteries are fully charged to start their battery charging. No more batteries than those listed above will ever charge at the same time. If a battery is removed and a discharged battery is inserted into a bay, that bay will move to the end of the charging sequence queue.

### **The average charging time to charge a fully discharged battery is:**

- 3.75 Hrs for a Dell rugged 5420/5424/5430/7330/7424 battery
- 3 Hrs for a Dell rugged 7202/7212/7220/7230 battery

Both battery type bays can be used in the same system.

### **With the charging times listed up to twice the number of batteries can be fully charged in an eight hour period by:**

As batteries become fully charged swapping them out with discharged batteries or having extra bays attached to the system (up to 16 bays total) that will charge their batteries as previous batteries become fully charged.

## OPERATION

Once the system is powered up and ready for use, the batteries can be inserted into the Charging Bays. Insert the batteries into the bays in the order you would like them to be charged. The master controller will charge the batteries in the order inserted. The number of bays charging simultaneously will be dependent on the power adapter being used. As these batteries become fully charged and no longer need the charging power, the Master Controller will select the next battery in the sequence to charge. If the charged battery is removed and another discharged battery is inserted into a bay that unit will move to the end of the sequence for charging. The Master Controller should have a green indicator on during normal operation.

### The Charging Bays will have:

- No indication if no battery installed.
- An amber indication if its battery is waiting for enough power to be freed up to start charging it.
- A slow blinking green indicator if the battery is charging and is at less than 80% charge.
- A fast blinking indicator if charging and battery is greater than 80% charged.
- A quick green blink once every 4 seconds if the battery is fully charged and ready for use.
- See “Indicators” section for other error indications.

**NOTE:** If the system is powered up with batteries already inserted into the Charging Bays the Master Controller will charge them starting with the bay closest to the Master Controller and the farthest bay being last. Any batteries added to any empty bays after this point will be moved to the end of the sequence. If power is lost all data the Master Controller has regarding battery charging sequence is lost.

## INDICATORS

### Master controller:

- Constant green = Normal operation.
- Two quick amber flashes followed by two quick green flashes = Unknown AC power adapter. Charging of batteries prevented. Use Dell AC power adapter or try removing power cord to Master Controller, waiting 10 seconds and re-plugging it back in.
- Blinking red = Ambient temperature of system is colder than 32°F (0°C) or hotter than 122°F (50°C). Charging of batteries is stopped. Resumes when back in normal temperature range.

### Charging Bay:

- No indicator = No battery in bay.
- Constant amber = Battery in bay but waiting for Master Controller to give it permission to charge.
- Quick green blink once every 4 seconds = Battery charged and ready for use.
- Fast blinking green = Battery charging and greater than 80% charged.
- Slow blinking green = Battery charging and less than 80% charged.
- Quick blinking amber = Battery failure, stopped charging if started.
- Four quick amber blinks followed by 4 quick green blinks = Temporary battery fault. Charging stopped if started. May resume if fault goes away. If fault persists for more than 30 seconds fault indication changes to battery failure indicated above. Note: this indication may be seen when a battery is first inserted into a bay if the battery circuitry has entered a sleep mode.
- Two quick amber flashes followed by two quick green flashes = Unsupported battery, no charging allowed
- Blinking red = Battery temperature is colder than 32°F(0°C) or hotter than 122°F(50°C). Charging of battery is stopped. Resumes when back in normal temperature range.

## ASSEMBLY

To assemble the Charging Bays together, push up against previous module and slide down to connect (see diagram below).

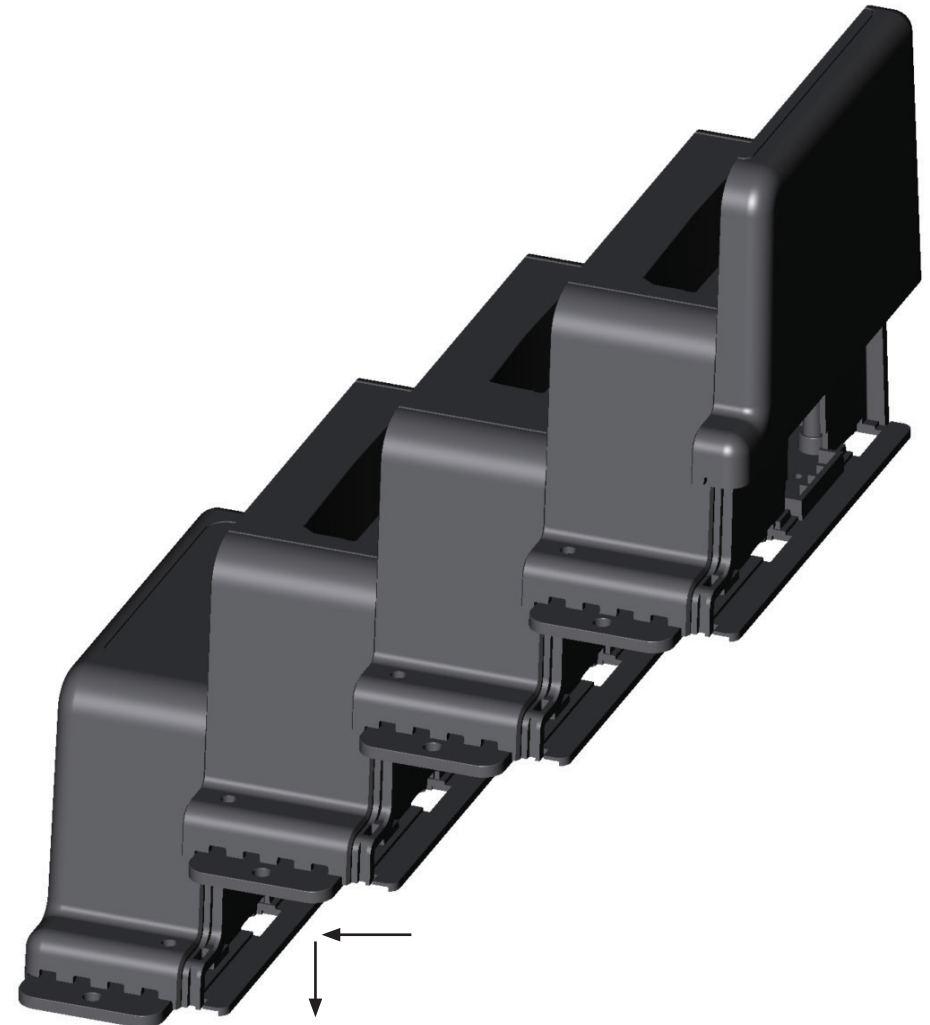

## DISASSEMBLY

**STEP 1:** Unplug the Dell AC power adapter from the Master Controller and remove all batteries from the Charging Bays. Turn the Charging System over so its bottom is facing up. Push the two locking fingers of the End Cap away from the Charging Bay it is attached to while also applying a slight downward pressure to these fingers until the End Cap disengages and slides partially off the Charging Bay. Slide the End Cap the rest of the way off and set aside.

**STEP 2:** Push the two locking fingers of the Charging Bay on the end away from the module it is attached to while also applying a slight downward pressure to these fingers until the Charging Bay disengages and slides partially off the Charging Bay. Slide the Charging Bay the rest of the way off and set aside.

**STEP 3:** If another Charging Bay is to be removed repeat step 2 until all Charging Bays have been removed.

**STEP 4:** Take the end cap from step 1 and align it with the side of the Master Controller and slide it down to fully seat it.

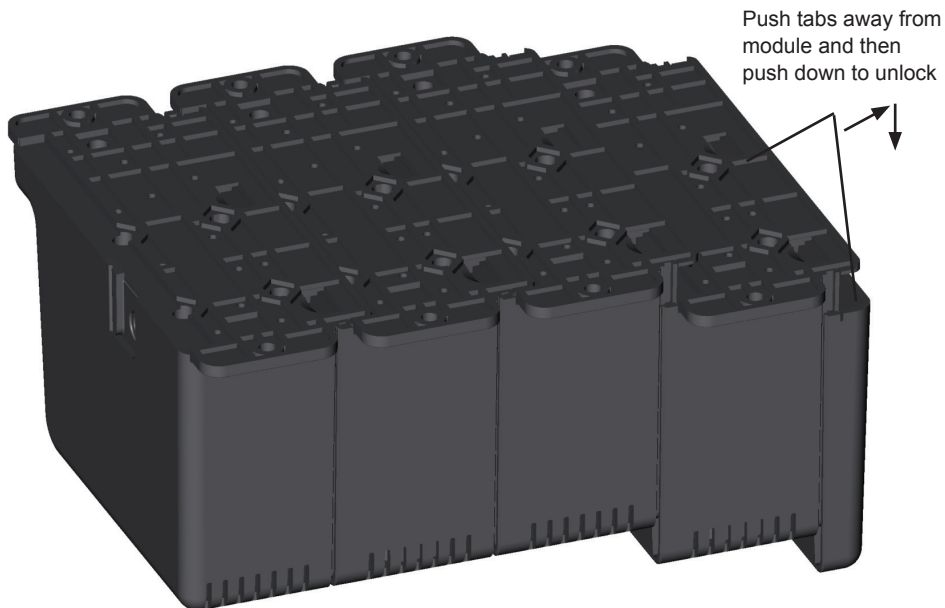

## MECHANICAL

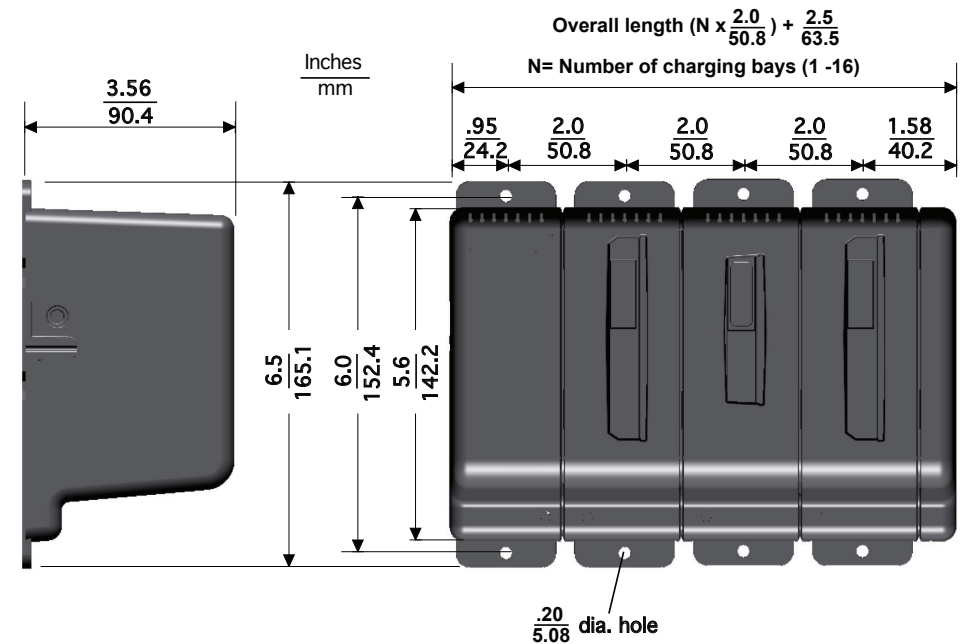

## SPECS

**Input power:**  
19.5VDC (330W max) from a Dell power adapter

**Battery charging:**  
32°F (0°C) to 104°F (40°C) ambient. Charging above 104°F (40°C) ambient may result in a temporary stoppage of charging if the battery exceeds 122°F (50°C). Once it cools down below 122°F (50°C), charging may resume.

**Battery bay options:**  
7202/7212/7220/7230 battery and 5420/5424/5430/7330/7424 battery charging bay

**Safety Agency Approvals:**  
IEC 60950-1, CB